



Electrolux

Modular Cooking Range Line 700XP One Well Electric Fryer Top 12 liter

ITEM # _____

MODEL # _____

NAME # _____

SIS # _____

AIA # _____



Electrolux



Modular Cooking Range Line

700XP One Well Electric Fryer Top 12 liter

371079 (E7FRED1E00) 12-lt electric fryer top with 1 well and 1 basket, internal heating elements

371142 (E7FRED1E0N) 12-lt electric fryer top with 1 well and 1 basket, internal heating elements

Short Form Specification

Item No. _____

Unit to be Electrolux 700XP One 12 lt well Electric Fryer Top. Unit to have high efficiency tilting incoloy heating elements inside the well. Electric characteristics to be ____ 400 V or ____ 230 V three phase. Unit to be installed on open base installations, bridging supports or cantilever systems. Unit to have deep drawn well. Oil drains through a tap on the front. Exterior panels of unit in Stainless steel with Scotch Brite finish. One piece pressed work top in 1.5 mm thick Stainless steel. Unit has right-angled side edges to allow flush-fitting junction between units.

Main Features

- Unit to be mounted on open base cupboards, bridging supports or cantilever systems.
- Deep drawn V-Shaped well.
- High efficiency tilting heating elements attached inside the well.
- Thermostatic regulation of oil temperature up to a maximum of 185 °C.
- Overheat protection thermostat as standard on all units.
- Oil drains through a tap positioned on the front the well.
- All major compartments located in front of unit for ease of maintenance.
- IPX 4 water protection.

Construction

- All exterior panels in Stainless Steel with Scotch Brite finishing.
- One piece pressed 1.5 mm work top in Stainless steel.
- Model has right-angled side edges to allow flush fitting joints between units, eliminating gaps and possible dirt traps.
- Interior of well with rounded corners for ease of cleaning.

APPROVAL: _____



Electrolux

Modular Cooking Range Line 700XP One Well Electric Fryer Top 12 liter

Included Accessories

- 1 of Basket for 12lt electric fryer tops PNC 921629

Optional Accessories

- Kit 4 wheels - 2 swivelling with brake - it is mandatory to install base support and wheels PNC 206135
- Support for bridge type installation, 800mm PNC 206137
- Support for bridge type installation, 1000mm PNC 206138
- Support for bridge type installation, 1200mm PNC 206139
- Support for bridge type installation, 1400mm PNC 206140
- Support for bridge type installation, 1600mm PNC 206141
- Support for bridge type installation, 400mm PNC 206154
- Chimney upstand, 400mm PNC 206303
- Right and left side handrails PNC 206307
- Base support for feet or wheels - 400mm (700/900) PNC 206366
- Base support for feet or wheels - 800mm (700/900) PNC 206367
- Rear paneling - 600mm (700/900XP) PNC 206373
- Rear paneling - 800mm (700/900) PNC 206374
- Rear paneling - 1000mm (700/900) PNC 206375
- Rear paneling - 1200mm (700/900) PNC 206376
- Chimney grid net, 400mm (700XP/900) PNC 206400
- Frontal handrail, 400mm PNC 216046
- Frontal handrail, 800mm PNC 216047
- Frontal handrail, 1200mm PNC 216049
- Frontal handrail, 1600mm PNC 216050
- Large handrail - portioning shelf, 400mm PNC 216185
- Large handrail - portioning shelf, 800mm PNC 216186
- 2 side covering panels for top appliances PNC 216277
- Basket for 12lt electric fryer tops PNC 921629
- 2 baskets for 2x5lt and 7lt electric fryers PNC 960638



Modular Cooking Range Line
700XP One Well Electric Fryer Top 12 liter

The company reserves the right to make modifications to the products without prior notice. All information correct at time of printing.

2014.08.29



Electrolux

Modular Cooking Range Line 700XP One Well Electric Fryer Top 12 liter

Front

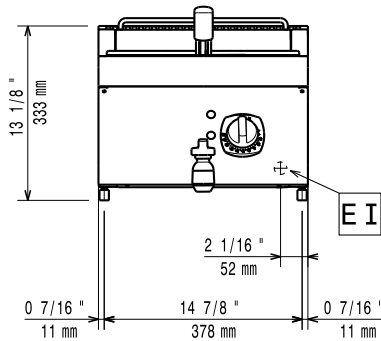

Top

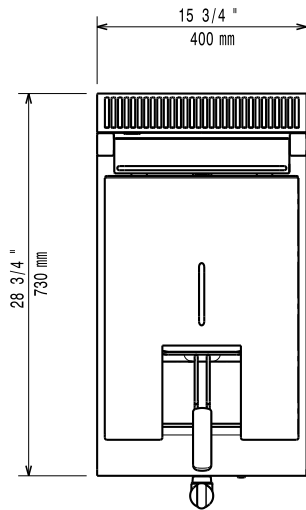

EI = Electrical connection
EQ = Equipotential screw

Side

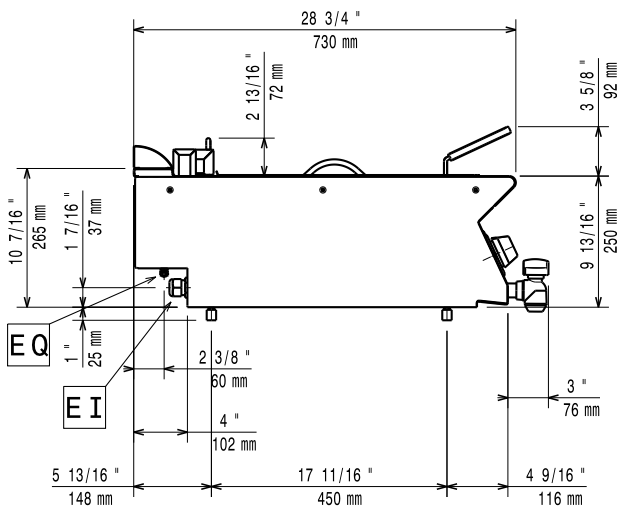

Electric

Supply voltage:

371079 (E7FRED1E00) 400 V/3N ph/50/60 Hz

371142 (E7FRED1E0N) 230 V/3 ph/50/60 Hz

Total Watts:

8.7 kW

Key Information:

Usable well dimensions (width):	240 mm
Usable well dimensions (height):	235 mm
Usable well dimensions (depth):	420 mm
Well capacity:	10 lt MIN; 12 lt MAX
Thermostat Range:	105 °C MIN; 185 °C MAX
Net weight:	25 kg
Shipping weight:	32 kg
Shipping height:	540 mm
Shipping width:	460 mm
Shipping depth:	820 mm
Shipping volume:	0.2 m ³

If appliance is set up or next to or against temperature sensitive furniture or similar, a safety gap of approximately 150 mm should be maintained or some form of heat insulation fitted.



Modular Cooking Range Line
700XP One Well Electric Fryer Top 12 liter

The company reserves the right to make modifications to the products without prior notice. All information correct at time of printing.