



# Electrolux

## Modular Cooking Range Line 900XP Full Module Electric Grill

ITEM # \_\_\_\_\_

MODEL # \_\_\_\_\_

NAME # \_\_\_\_\_

SIS # \_\_\_\_\_

AIA # \_\_\_\_\_



Electrolux



Modular Cooking Range Line

900XP Full Module Electric Grill

391271 (E9GREHGCFU)

Full module electric grill free standing

### Short Form Specification

Item No. \_\_\_\_\_

Heating via incoloy armoured heating elements positioned under the cooking grid. Cooking surface grids in cast iron, easily removable for cleaning. Cast iron grids can be rotated for the grilling of fish or meats. Includes drip tray for the collection of grease and fat. Exterior panels of unit in stainless steel with Scotch Brite finish. Extra strength work top in heavy duty 2 mm stainless steel. Right-angled side edges to allow flush-fitting junction between units.

### Main Features

- Incoloy armoured heating elements positioned under the cooking grid.
- Each bank of elements has a temperature controlled thermostat.
- Power indicator light.
- Cast iron grids can be rotated on the right ribbed profile, to grill fish or meats.
- Drip tray to collect residual cooking juices and fat.
- Stainless steel high splash guards on the rear and sides of cooking surface. Splash guards can be easily removed for cleaning and are dishwasher-safe.
- The special design of the control knob system guarantees against water infiltration.
- IPX5 water protection.
- Energy regulation through a control knob.
- Heating element can be tilted frontally for easy cleaning.
- Monoblock structure gives better stability and easier installation.
- The cooking surface is double-sided: one for meat and the other for fish and vegetables.
- The drawer can be filled with water to obtain vapor to cook softer food and to facilitate the cleaning of the drawer.
- The low temperature of the external panels allow to work in safety.

### Construction

- Unit is 930 mm deep to give a larger working surface area.
- All exterior panels in Stainless Steel with Scotch Brite finishing.
- AISI 304 stainless steel worktop, 2mm thick.
- Model has right-angled side edges to allow flush fitting joints between units, eliminating gaps and possible dirt traps.

### Optional Accessories

- Junction sealing kit  PNC 206086
- Kit 4 wheels - 2 swivelling with brake  PNC 206135  
- it is mandatory to install base support and wheels
- Flanged feet kit  PNC 206136
- Frontal kicking strip for concrete installation, 800mm  PNC 206148
- Frontal kicking strip for concrete installation, 1000mm  PNC 206150
- Frontal kicking strip for concrete installation, 1200mm  PNC 206151
- Frontal kicking strip for concrete installation, 1600mm  PNC 206152

APPROVAL: \_\_\_\_\_

- Pair of side kicking strips for concrete installation PNC 206157
- Kit 4 feet free standing grill for installation on concrete socle PNC 206163
- Frontal kicking strip, 800mm (not for refr-freezer base) PNC 206176
- Frontal kicking strip, 1000mm (not for refr-freezer base) PNC 206177
- Frontal kicking strip, 1200mm (not for refr-freezer base) PNC 206178
- Frontal kicking strip, 1600mm (not for refr-freezer base) PNC 206179
- Pair of side kicking strips (not for refr-freezer base) PNC 206180
- 2 panels for service duct for single installation PNC 206181
- Frontal panel for 800mm free standing grill PNC 206198
- 2 panels for service duct for back to back installation PNC 206202
- 2 side panels for free standing grill PNC 206207
- Water filling tap for 800 mm free standing grills PNC 206281
- Water column with swivel arm (water column extension not included) PNC 206289
- Chimney upstand, 800mm PNC 206304
- Base support for feet or wheels - 800mm (700/900) PNC 206367
- Stainless steel grid for free standing grills (900XP) PNC 206404
- Stainless steel grid with drainage channels for free standing V-shaped grills (900XP) PNC 206405
- Scraper for grids with drainage channels - top grills PNC 206421
- Scraper for free standing grills PNC 206422
- Side handrail-right/left hand (900XP) PNC 216044
- Frontal handrail, 800mm PNC 216047
- Frontal handrail, 1200mm PNC 216049
- Frontal handrail, 1600mm PNC 216050
- Large handrail - portioning shelf, 400mm PNC 216185
- Large handrail - portioning shelf, 800mm PNC 216186



# Electrolux

## Modular Cooking Range Line 900XP Full Module Electric Grill

Front

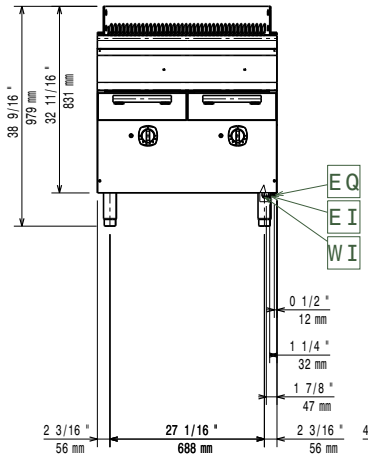

Top

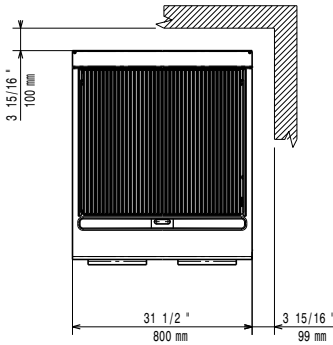

Side

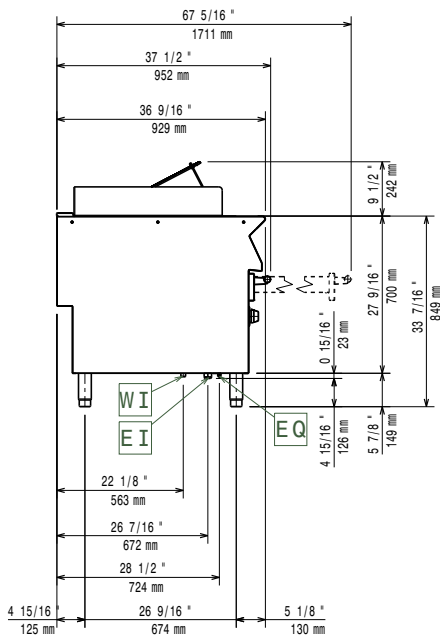

EI = Electrical connection  
EQ = Equipotential screw

### Electric

Supply voltage:	391271 (E9GREHGCFU)	400 V/3N ph/50/60 Hz
Electrical power:		15 kW
Total Watts:		15 kW

### Key Information:

External dimensions, Height:	850 mm
External dimensions, Width:	800 mm
External dimensions, Depth:	930 mm
Net weight:	94 kg
Shipping weight:	115 kg
Shipping height:	1180 mm
Shipping width:	1020 mm
Shipping depth:	860 mm
Shipping volume:	1.04 m <sup>3</sup>

If appliance is set up or next to or against temperature sensitive furniture or similar, a safety gap of approximately 150 mm should be maintained or some form of heat insulation fitted.

Modular Cooking Range Line  
900XP Full Module Electric Grill

The company reserves the right to make modifications to the products without prior notice. All information correct at time of printing.

