

Gas Pasta Cookers

The 700XP range is comprised of over 100 models designed to guarantee the highest level of performance, reliability, energy saving, safety standards and ergonomic operation. These concepts are reflected throughout the line in its modularity, construction and numerous configurations: countertop (on base or table), free-standing, on concrete or stainless steel socle, bridged or cantilever. Thanks to its advance technology and premium performance, 700XP is a perfect solution for institutions of small sizes with limited footprint as well as restaurants needing to obtain the most from the kitchen space. The models detailed in this sheet are freestanding gas pasta cookers.



371090

EASY TO INSTALL

- Main connections are accessible from the base or rear of the unit.
- Access to all components from the front.
- No electrical connection needed.
- ESD available as accessory to be installed separately: the energy saving device uses the heat still present in the water drained through the overflow to pre-heat the tap-in water up to 60°C, thus ensuring constant water boiling.

EASY TO CLEAN

- Well in AISI 316-L stainless steel is seamlessly welded into the top of the appliance and guarantees high resistance against the aggressive environment caused by the salty hot water.

- One piece pressed worktop in 1,5mm stainless steel with smooth, rounded corners.
- Exterior panels in stainless steel with Scotch Brite finish.
- All models have right-angled, laser cut side edges to allow flush-fitting joints between units eliminating gaps and possible dirt traps.
- Feet in stainless steel are adjustable up to 50 mm in height.

EASY TO USE

- The freestanding gas pasta cooker is the ideal appliance for restaurants and large institutions needing high power and productivity. The pasta cooker may also be used to steam small quantities of food with the use of optional

accessories: perforated GN containers and lids. This unit does not require electrical connection.

- Unique **EnergyControl** feature: precisely regulates the boiling level and optimizes energy consumption.
- Easy to use control panel with safety gas cock, piezo ignition and water tap.
- Safety Thermostat to prevent the machine from running without water.
- Large drain controlled through a manual ball-valve for fast emptying of the well.
- All gas appliances are supplied for use with natural gas or LPG. Conversion jets supplied as standard.



Electrolux

**700XP
Gas Pasta Cookers**

- The overflow guarantees the skimming of the foam and starches through the continuous water filling which is regulated through the manual water tap.
- Optional accessory: automatic lifting system allowing to transform a regular gas or electric pasta cooker into one with automatic basket lifting. The electronic programmability and automatic lifting of the baskets make this unit a must for any kitchen wanting to standardize their cooking procedures. Possibility to memorize nine cooking times through digital control. Automatic basket lifting through push button function. Two stainless steel basket supports, each capable of holding one 170x220mm basket.

The unit may either be placed individually on either side of the pasta cooker, or two units may be installed (one on each side of the pasta cooker) to provide lifting for four single portion baskets (optional baskets to be ordered separately).

EASY TO MAINTAIN

- IPX4 water protection.
- The special design of the control knobs and bezels guarantees against water infiltration.

EASY ON THE ENVIRONMENT

- 98% recyclable by weight.
- CFC free packaging.

*In accordance with CE regulations for gas models belonging to Class B11 (power over 14 kW), it is necessary to install a chimney (if installed under a hood) or chimney and draft diverter if the waste gases are vented directly outside.

CHGA010

2011-11-11

Subject to change without notice

	E7PCGD1KF0 371090	E7PCGH2KF0 371091
TECHNICAL DATA		
Power supply	Gas	Gas
External dimensions - mm		
width	400	800
depth	730	730
height	850	850
height adjustment	50	50
N° of wells	1	2
Usable well dimensions - mm		
width	250	250
depth	400	400
height	300	300
Thermocouple safety valve	●	●
Temperature limiter	●	●
Maximum Well Capacity -lt	18, 24.5	18, 24.5
Power - kW		
gas	11.5	23
Net weight - kg.	50	50

**700XP
Gas Pasta Cookers**

	E7PCGD1KF0 371090	E7PCGH2KF0 371091
INCLUDED ACCESSORIES		
DOOR FOR OPEN BASE CUPBOARD-ELUX	1	2
ACCESSORIES		
2 BASKETS 105X350 FOR PASTA COOKERS	921619	921619
2 BASKETS 170X220 FOR PASTA COOKERS	921610	921610
2 SIDE COVERING PANELS H=700 D=700-ELUX	216000	216000
2 SIDE KICKING STRIPS - 700 LINE	206249	206249
2 SIDE KICKING STRIPS-CONCRETE INST-700	206265	206265
4 BASKETS 105X160 FOR PASTA COOKERS	921618	921618
4 FEET FOR CONCRETE INSTALLATION	206210	206210
4 WHEELS (2 WITH BRAKE)		206188
AUTO.LIFTING(200MM)PASTA COOKER 700 ELUX	206352	206352
BASKET 350X220 FOR PASTA COOKERS	921611	921611
CHIMNEY COVER 400MM OPEN	206284	
CHIMNEY UPSTAND 400MM	206303	
CHIMNEY UPSTAND 800MM		206304
DOOR FOR OPEN BASE CUPBOARD-ELUX	206350	206350
DRAUGHT DIVERTER WITH 120 MM DIAMETER	206126	
DRAUGHT DIVERTER WITH 150 MM DIAMETER		206132
ENERGY SAVING DEVICE-PASTA COOK. 700/900	206344	206344
FLANGED FEET KIT	206136	206136
FLUE CONDENSER FOR 1 MODULE DIAM.150MM		206246
FLUE CONDENSER FOR 1/2 MOD. DIAM.120MM	206310	
FRONT.KICK.STRIP F.CONCRETE INST.1000 MM	206150	206150
FRONT.KICK.STRIP F.CONCRETE INST.1200 MM	206151	206151
FRONT.KICK.STRIP F.CONCRETE INST.1600 MM	206152	206152
FRONT.KICK.STRIP F.CONCRETE INST.200 MM	206146	206146
FRONT.KICK.STRIP F.CONCRETE INST.400 MM	206147	206147
FRONT.KICK.STRIP F.CONCRETE INST.800 MM	206148	206148
FRONTAL HANDRAIL 1200 MM	216049	216049
FRONTAL HANDRAIL 1600 MM	216050	216050
FRONTAL HANDRAIL 400 MM	216046	
FRONTAL HANDRAIL 800 MM	216047	216047
FRONTAL KICKING STRIP 1000 MM	206177	206177
FRONTAL KICKING STRIP 1200 MM	206178	206178
FRONTAL KICKING STRIP 1600 MM	206179	206179
FRONTAL KICKING STRIP 200 MM	206174	206174
FRONTAL KICKING STRIP 400 MM	206175	206175
FRONTAL KICKING STRIP 800 MM	206176	206176
LARGE HANDRAIL(PORTIONING SHELF)400 MM	216185	216185
LARGE HANDRAIL(PORTIONING SHELF)800 MM	216186	216186
LID FOR PASTA COOKERS	921607	921607
MATCHING RING FOR FLUE CONDENSER 150DIAM		206133
MATCHING RING-FLUE CONDENSER 120-130DIAM	206127	
PRESSURE REGULATOR FOR GAS UNITS	927225	927225
SIDE HANDRAIL-RIGHT/LEFT HAND-700 LINE	206307	206307
SUPPORT FOR 4 PASTA COOKER BASKETS	921606	921606
WATER COLUMN EXTENSION FOR 700 LINE	206291	206291
WATER COLUMN WITH SWIVEL ARM	206289	206289

CHGA010

2011-11-11

Subject to change without notice

700XP
Gas Pasta Cookers

371090

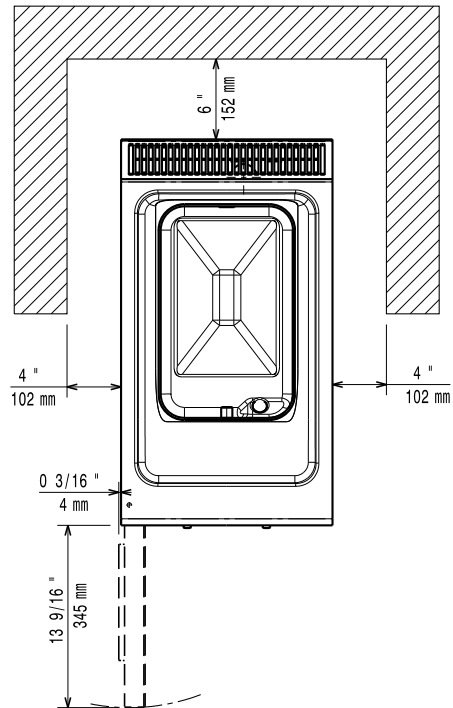
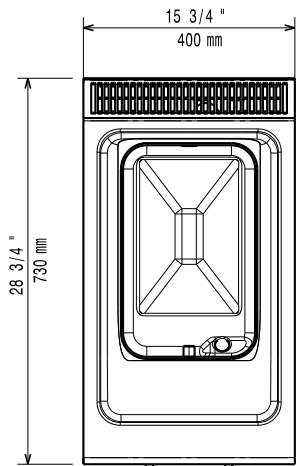
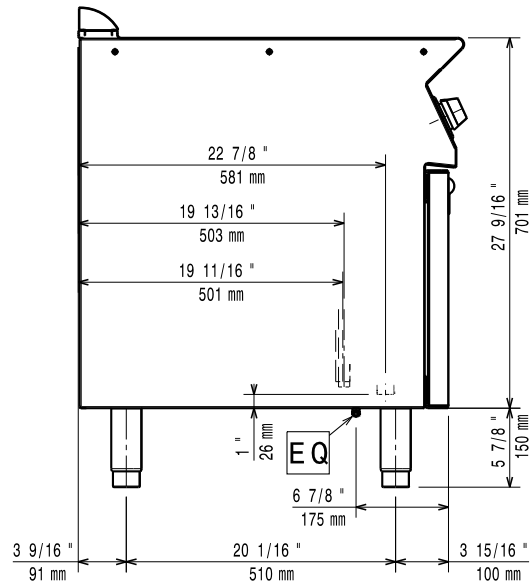
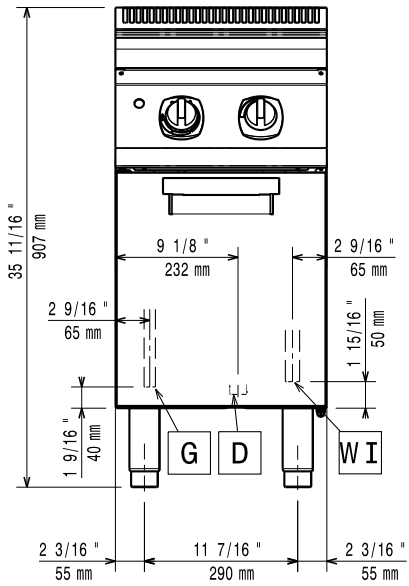

LEGEND		E7PCGD1KF0 371090
CWI - Cold water inlet		1/2"
D - Water drain		1"
G - Gas connection		1/2"

CHGA010

2011-11-11

Subject to change without notice

700XP
Gas Pasta Cookers

371091

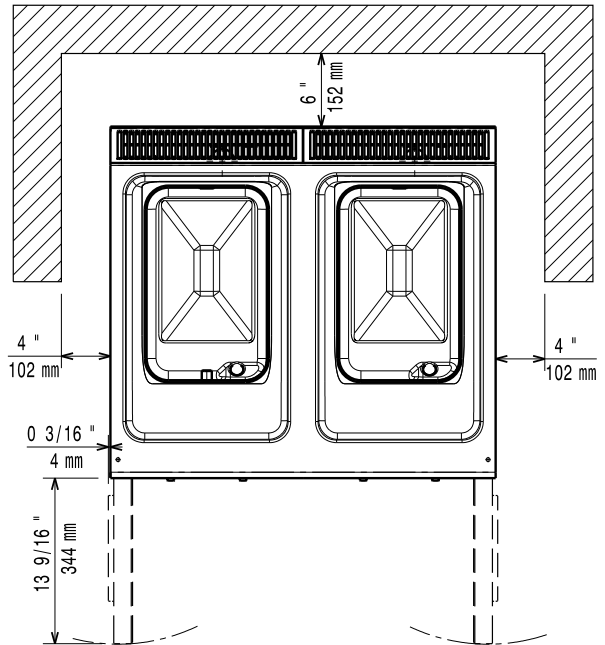
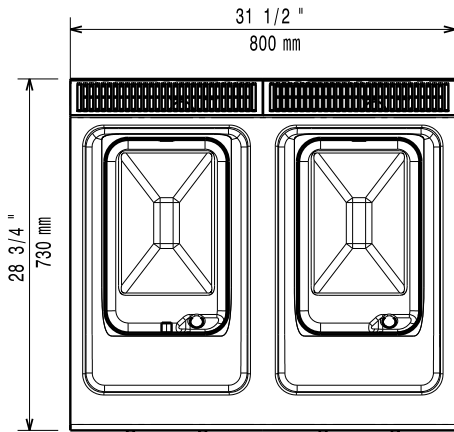
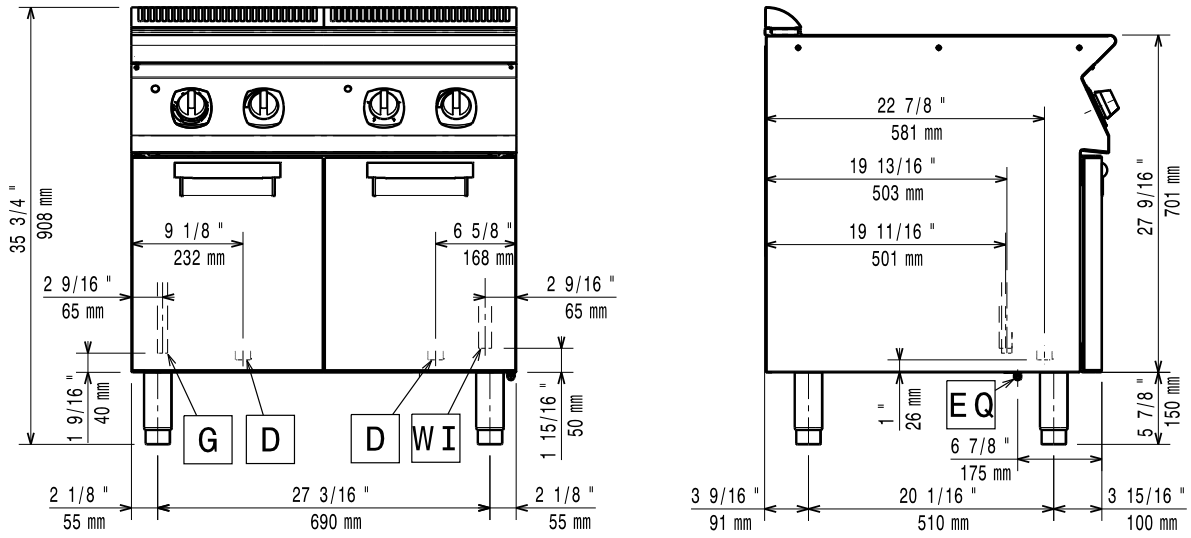

LEGEND		E7PCGH2KF0 371091
CWI - Cold water inlet		1/2"
D - Water drain		1"
G - Gas connection		1/2"

2011-11-11

CHGA010

Subject to change without notice