



Electrolux

Modular Cooking Range Line 900XP Electric Bratt Pan 100lt with mild steel bottom

ITEM # _____

MODEL # _____

NAME # _____

SIS # _____

AIA # _____



Electrolux



Modular Cooking Range Line
900XP Electric Bratt Pan 100lt with
mild steel bottom

391147 (E9BREJMPF0)

900XP Electric Bratt Pan –
100 liter with mild steel bottom

Short Form Specification

Item No. _____

Infrared heating elements positioned under the cooking surface. Polished mild steel plated cooking surface for roasting, browning, stewing, preparation of sauces, sautéing, boiling and braising. To be installed on stainless steel feet with height adjustment up to 50 mm and can be installed on cantilever systems. Includes mechanism to manually tilt the pan and double-skinned lid in stainless steel. Cooking temperature can be set through thermostat and the energy input through an energy regulator.

Exterior panels of unit in stainless steel with Scotch Brite finish. Right-angled side edges to allow flush-fitting junction between units.

Main Features

- Double-skin well and lid to reduce heat dispersion.
- Infrared heating elements mounted below the cooking surface.
- Lid is double-lined, insulated in 20/10 Stainless steel.
- IPX5 water resistance certification.
- Actual cooking temperature setting through adjustable thermostat.
- Working temperature can be set from 120 °C to 300 °C.
- Energy input controlled by energy regulator.
- Heat-insulated: limited heat radiation and low energy consumption.
- Manual tilting mechanism to facilitate pan emptying.
- Smooth large surfaces, easy access for cleaning.
- The special design of the control knob system guarantees against water infiltration.
- Unit to be mounted on stainless steel feet with height adjustment up to 50 mm. Unit can be easily mounted on cantilever systems.

Construction

- Cooking surface in mild steel for sautéing, poaching, steaming, boiling, stewing and regular frying.
- All pan internal surfaces round and polished.
- All exterior panels in Stainless Steel with Scotch Brite finishing.
- Model has right-angled side edges to allow flush fitting joints between units, eliminating gaps and possible dirt traps.

Optional Accessories

- Flanged feet kit PNC 206136
- Kit 4 feet free standing grill for installation on concrete socle PNC 206163
- Pair of side kicking strips (not for refr-freezer base) PNC 206180
- 2 panels for service duct for single installation PNC 206181
- 2 panels for service duct for back to back installation PNC 206202

APPROVAL: _____



Electrolux

Modular Cooking Range Line 900XP Electric Bratt Pan 100lt with mild steel bottom

Front

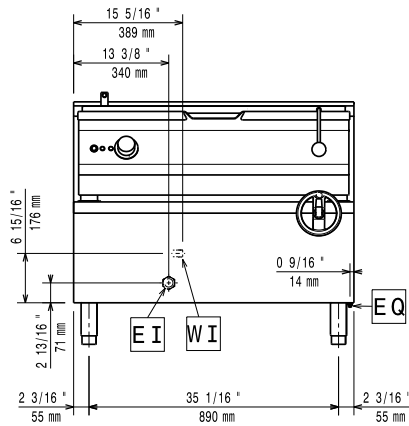

Top

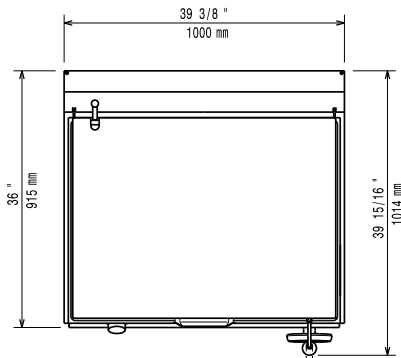

CWI

= Cold Water inlet

EI = Electrical connection

Side

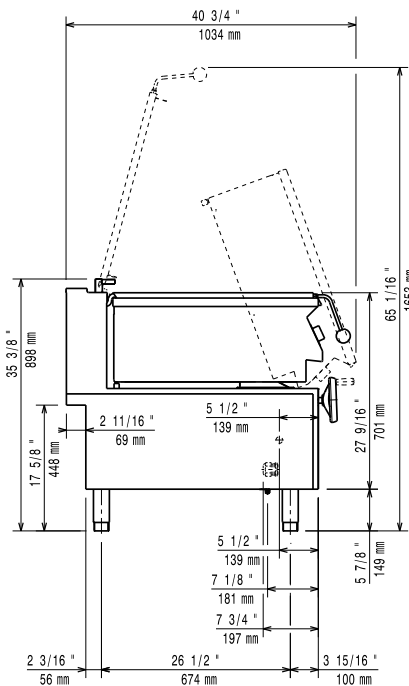

Electric

Supply voltage:

391147(E9BREJMPF0)

400 V/3N ph/50/60 Hz

Total Watts:

17 kW

Key Information:

Cooking Surface Depth: 565 mm

Cooking Surface Width: 880 mm

Cooking Well Height: 130 mm

Well Capacity, Max: 100 lt

Working Temperature MIN: 120 °C

Working Temperature MAX: 300 °C

Net weight: 180 kg

Shipping weight: 200 kg

Shipping height: 1040 mm

Shipping width: 1100 mm

Shipping depth: 1020 mm

Shipping volume: 1.17 m³

No clearance needed on rear sides of unit if wall is of non combustible type. If wall is combustible, minimum 50 mm wall clearance should be maintained.



Modular Cooking Range Line
900XP Electric Bratt Pan 100lt with mild steel bottom

The company reserves the right to make modifications to the products without prior notice. All information correct at time of printing.